

---

## SECTION 4 DEFINITIONS

The following is a list of terms and meanings used by the LTA.

### **4.A AIR DUCT:**

Aerodynamic pressure relief systems in which air is ducted from one point to another. Air ducts may pierce, but shall not extend past exterior bodywork and shall not be utilized to eliminate a prominent feature (e.g. a fender crown shall not be removed to provide a duct opening). Air ducts shall originate and exit in the rear 50% of the vehicle body and shall not be directed to or away from wheel wells. Construction shall be of nonflammable materials.

### **4.B AIR INTAKES:**

Ducted airflow devices, which are meant to provide combustion air directly to the engine. Air intakes shall not originate below the original stock location and, on rear engine cars, the air intake must originate in the rear 50% of the body. Air intakes protruding from the front of the car (other than OEM) must not exceed 48 sq. in. of frontal area and must not extend more than 12 in. and must not taper, except in classes where forward streamlining is allowed. Carburetors that protrude through the car hood must be covered with a shield.

### **4.C AIR VENTS:**

Aerodynamic pressure relief systems in which no air ducting is utilized. Louvers and tail light removal fall under this definition.

### **4.D AUTOMOBILE:**

For classification purposes, an automobile is a land vehicle propelled by its own means, run on at least four (4) wheels not aligned, which shall always be in contact with the ground. Steering must be assured by at least two (2) front wheels. The automobile must be propelled by at least two (2) wheels. One pair of wheels shall be on the same transverse centerline.

### **4.E AUTOMOTIVE PRODUCTION:**

Any component which is offered for sale by a recognized automotive manufacturer to the general public as original equipment or accessory to a production automobile is considered automotive production. A production rate of at least 500 vehicles of the same model and year for sale to the general public is considered to meet the requirement of a production automobile.

### **4.F BALLAST:**

Material added to the vehicle for the purpose of additional weight only. Heavy components which serve another function will be identified by that function.

### **4.G BELLY PAN:**

A skin of material used to cover the undercarriage of a vehicle. The skin must cover at least 51% of the undercarriage of the vehicle to be considered a belly pan for classification purposes. DRAIN HOLES ARE REQUIRED IN THE ENGINE AREA.

### **4.H BOBBING:**

The removal of material from a body component in such a fashion as to destroy the original shape at either the top or bottom.

### **4.I CHOPPING:**

The removal of metal from a body component in such a fashion as to reduce the overall height of the component without changing the original shape at either the top or bottom.

#### **4.I.1 CHANNELING:**

The lowering of the body over the frame rails.

---

#### **4.J CONTEST BOARD:**

The Board of Directors of LTA plus additional personnel appointed by the LTA.

#### **4.K CONTOUR:**

Contour is the configuration of the external sheet metal and windows. All body panels and windows shall be mounted in their original relationship as manufactured unless otherwise allowed.

##### ALLOWED:

- A: Removal of trim, lights, windows, floorboards, and interior sheet metal.
- B: In the special case of chopped tops, contour is considered to have been preserved as long as the angular relationship of the top to the body proper is not changed.

##### NOT ALLOWED:

- A: Moving body panels and windows from original relationships to control air.
- B: Tightening of gaps, filling seams with caulk or foam tape.
- C: Altering the original panel shape.

#### **4.L COVERED WHEEL:**

For classification purposes, a wheel will be considered covered if 120 degrees of the tread circumference is shielded from the air stream by the covering.

#### **4.M DRIVER/RIDER COMMITTEE:**

This Committee will consist of at least two Board members and a minimum of three non-Board members and will be responsible for licensing review and related matters.

#### **4.N ENGINE SWAP:**

An engine swap is defined as when an engine from an engine design family that was not available as a factory or dealer installed option for a given vehicle year is used.

An engine design family is defined as engines which are made with the same basic material, have the same bore centers, crank shaft supports, deck height, cam location, head mounting, bell housing and engine mount patterns, etc. All OEM parts must fit the block without modification.

- A: The use of an OEM or aftermarket replacement engine block from the same design family is not considered a swap.
- B: "Crate engines" are not considered engine swaps.
- C: Direct replacement aftermarket engine blocks are not considered engine swaps (Dart, World Products, etc.), if they meet the above engine swap design definition criteria.

#### **4.O FIREWALL: (NON-PRODUCTION)**

A metal barrier between the engine and driver compartment, see Section 3.F.

#### **4.P FLOORBOARDS:**

Floorboards are defined as paneling in the lower portion of the car exclusive of the engine compartment. Floorboards shall be mounted above the frame or in the stock location for the body style and year of the vehicle. Floorboards shall be inside or over all suspension and drive line components, well fitted and securely attached with all holes sealed.

#### **4.Q GASOLINE:**

Gasoline, as produced, is a mixture of hydrocarbons which may include some LTA acceptable oxygenates. The LTA further defines gasoline as a liquid that does not contain nitrogen bearing compounds, nor propylene oxide, nor ethylene oxide, and no more than 10% methanol.

**4.R HOOD SCOOPS:**

A hood scoop is a functional air intake device used on full body, un-blown vehicles, where allowed. No part of a forward facing hood scoop can extend forward of the leading edge of the hood, be more than 11" above the surface of the hood at the centerline or extend past the trailing edge of the hood more than 11". Clearance between scoop and windshield must be a minimum 1/2".

On rearward facing scoops they cannot be more than 11" above the surface of the hood at the centerline. They can extend past the trail edge of the hood but the rear must be totally open and clearance between scoop and the windshield must be of 2". No foam sealing is allowed between the scoop and windshield. On rear engine cars the hood scoop may be built on the engine cover. The scoop shall not extend more than 11 in. above the surface of the roof and no further forward than the front edge of the back window.

**4.S INCIDENT REVIEW COMMITTEE:**

This Committee will consist of 2 Board members and appointed non-Board members to review and report to the Board on a specific incident, as requested by the Board.

**4.T RESERVED:****4.U LIMB RESTRAINT:**

A restraint system capable of containing the driver's arms and legs within the inner plane of the roll structure in case of an incident that includes vehicle body panel separation.

**4.V OPEN CAR:**

Any car, which may be entered and exited without unfastening, unlatching or moving any panel. All open cars as described MUST have the driver's line-of-sight above the body (Special Construction Excluded). No periscopes allowed.

**4.W OPEN WHEEL:**

A wheel configuration in which no portion of the car's bodywork intrudes upon the inside plane of the tire.

**4.X ROOF RAILS:**

A piece of metal angle, perpendicular to the roof, and a minimum of 1/2 in. high to a maximum of 3/4 in. high. The roof rail must be attached to the roof on each side, as close to the outside edge as possible. The roof rails must be parallel from the front to the rear. The roof rails may extend from the base of the windshield to the base of the rear window. Roof rails may be installed on any vehicle in classes CC, ALT, GC, MS, PRO, PS and GT ONLY where the original body style is a coupe or sedan. Roof rails are REQUIRED when the existing class records exceeds 200 MPH. Roof rails will not be considered for classification purposes.

**4.Y SECTIONED:**

The removal of a given horizontal width of a body panel and rejoining the body panel to achieve a lower height.

**4.Z SECONDARY FLOORING:**

Metal sheeting in the driver's compartment for the purpose of retaining the driver and appendages in the event of step pan or belly pan tear away. Not required in cars with floorboards in the cockpit.

**4.AA SET BACK:**

The feature of a car which is represented by the formula D/WB where D is the distance measured from the front spindle transverse centerline to the front-

most spark plug hole or centerline of the front most cylinder on compression ignition engines and WB is the wheelbase.

#### **4.BB WINDSHIELD POST MOUNTING SUPPORT:**

An upright bar, post or support structure to which the windshield posts are bolted, i.e., 1928- 1931 and Ford roadsters have this piece, 1926 -1927 and 1932-1934 Ford roadsters do not.

#### **4.CC STREAMLINING:**

Any device which has the apparent purpose of directing, limiting, or controlling air flow around or within the car and was not a part of the original body will be considered as streamlining.

Removal of certain devices may also be considered streamlining; axle and header configuration will not. Any streamlining devices will be considered as part of the body for classification purposes, see Section 2.J. The types of streamlining devices listed below are allowed in some classes:

##### **4.CC.1 AIR DAMS and SPLITTERS:**

OEM or fabricated devices installed below the front bumper used to inhibit and direct airflow from under the vehicle. **An air dam may be attached to the leaded the leading edge of the bumper and not be considered to be extending forward of the front bumper so long as no point of the air dam projects more than 1/4" forward of the original contour of the leading edge of the front bumper when viewed from above.** Splitters are allowed as long as they follow the same contours requirements as an air dam. Bodies cannot be cut away to accommodate air dams or splitters. The front air dam or splitter may not come in contact with the racing surface at any time. It is the competitor's responsibility to insure that their vehicle meets this rule when the front suspension bottoms out.

##### **4.CC.2 Axle Fairing:**

Streamlining devices attached to the axle to direct airflow around axle configuration only.

##### **4.CC.3 Belly Pan:**

A skin of material used to cover the undercarriage of a vehicle.

##### **4.CC.4 Headrest Fairing:**

Bodywork, on an open car, Section 4.V, which extends rearward for the purpose of preventing wind buffeting of the driver. The fairing shall not be wider than the roll cage at any point, nor extend past the rearmost part of the body.

##### **4.CC.5 Skirts:**

Streamlining devices added to the lower portion of the body for the purpose of controlling airflow under the body. The skirt may be a maximum 1/2 in. thick. The skirt shall be in a single plane, mounted to the bottom of the body but cannot modify the contour of the body. The skirts may extend from the centerline of the front axle to a vertical plane at the rearmost point of the original bodyline.

##### **4.CC.6 Spoiler:**

A device on the upper portion of the body for the purpose of spoiling lift. It shall be mounted in the rear portion of the body behind the rear axle centerline. Two different designs can be used but not mixed together. See figures 11 and 12. **Should a competitor wish to use a different approach to a spoiler implementation, that approach must be submitted to the**

**Technical Committee for review and consideration prior to the race event.**

**DESIGN ONE:** The spoiler must have a **continuous** surface no wider than the outside edge of the rear tires. The maximum chord measured on the top surface at the center of the car can be 10". A 1 in. tab or hinge can be added to the leading edge of the spoiler for the mounting purposes only. A spill plate on each side of the spoiler is allowed and must be **mounted** parallel to each other vertically and horizontally. It can extend **no further forward than** to the rear axle centerline. Spill plates are allowed to be **no more than 8 in.** above and below the forward mounted position of the spoiler when **the spoiler is parallel with the ground** and extend **no more than 2 in.** max past the end of the spoiler. No appendages or holes that direct air are allowed on/in the spill plates. Gurney flaps are allowed but cannot extend above or behind the spill plates. **The design** allowed to fill the horizontal gap between the leading edge of the spoiler and the body with a plate no farther forward than the centerline of the rear axle.

**DESIGN TWO:** The spoiler must have a single **continuous** surface with no side plates. Maximum spoiler chord measured on the top surface is 10 in. from the trailing edge of the body. A 1 in. tab can be added to the lead edge of the spoiler for mounting purposes only. The ends of the spoiler must follow the contour of the body and shall not extend beyond the outside edges of the body at any point. When laid flat the width of the spoiler can be a **no more than 16 in.** wider than the outside plane of the rear tires. No other aero devices or Gurney Flap are allowed with this design.

5

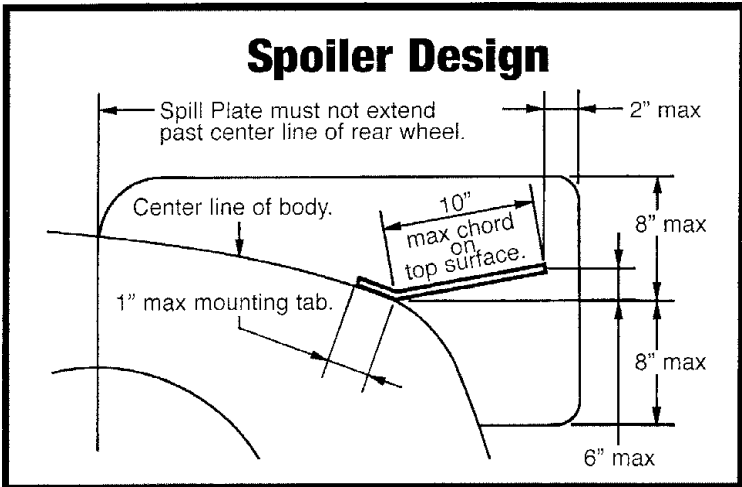

## Alternate Spoiler Design

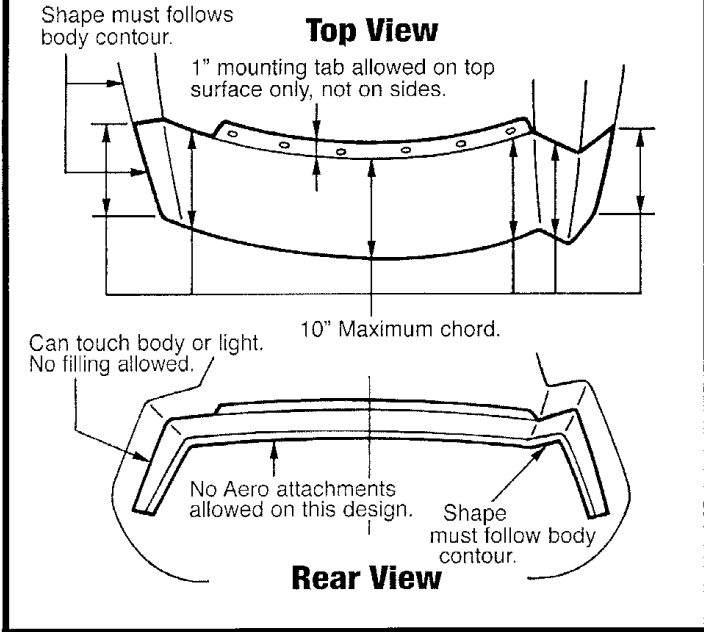

6

### 4.CC.7 Trip Fences:

A device in the upper forward part of the body to tripping the laminar layer.

### 4.CC.8 Vortex Generators:

Sharp edged devices placed on the body to create flow vortices.

### 4.CC.9 Wings:

Wings are a special class of aerodynamic effect devices intended to provide down force, which are allowed ONLY on Streamliners, Lakesters, Modified Roadsters **Competition Coupes** and Production bodies which had the wing as an option. For classification purposes, the wing is not considered as part of the body.

### 4.CC.10 Parachute Pack Mounts:

A parachute pack mounting plate must not extend more than 1" past the edge of the Parachute bag on all sides. The maximum length on all sides supporting the mounting plate shall be 6". If two chutes bags are mounted side by side on the same plate the max space allowed between them is 4". No more than two chutes can be mounted on one mounting plate. If the pack mount/mounts have to be more than 6" of the body a tube structure must support the mounting plate/plates.

### 4.CC.11 Parachute Mounting Tubes:

Parachute mounting tubes may extend no further than 6" behind the rearmost part of the original body and must not be faired into the body. The maximum

length of any side of a tube extending from the body is 12". These dimensions are dependent on specific class rules.

#### **4.CC.12 Strake:**

Strake is an aerodynamic device **located under the rear portion of the vehicle** at the rear of the vehicle **that is intended to** direct air flow under the vehicle. The strake **may extend** no further back than the trailing edge of the body, **and must be** perpendicular to the ground and parallel to the center line of the vehicle. The strake **may be located** no further out than the inner plane of the rear tires and **may extend** no further forward than **the firewall or body cowl line, whichever is further forward**. Strakes that are OEM and do not meet this definition are allowed.

#### **4.DD STREET EQUIPMENT:**

That equipment required for legal street operation in most states. It includes, but is not limited to, high and low beam headlights, horn, taillights, stoplights, signal lights, windshield wipers, and an exhaust system capable of being muffled. Decals do not meet the head and tail light requirements.

#### **4.EE STEP PAN:**

A step pan may enclose the area from the aft-most portion of the firewall to a line 10 in. forward of the rear axle centerline and shall not be lower than the frame at any point plus the thickness of the material used.

The step pan shall be flat, parallel to the ground (side to side) and no wider than the frame rails. A box may be constructed to enclose the portion of the transmission which protrudes through the step pan. The box must be rectangular in design, flat on the bottom, covering only the exposed portion of the transmission. The box shall not be tapered in any way; maximum clearance from the transmission shall be 1 in. Chassis cross members are not considered as part of the frame for purposes of this rule. The transition at the rear of the step pan to the floorboard shall occur at a 45 degree or steeper angle to be exempted from the definition of a belly pan.

NOTE: A step pan shall not be considered part of a belly pan for classification.

#### **4.FF SUPERCHARGED:**

For purposes of classification, Blown (supercharged) will be an artificially aspirated engine with a mechanically driven supercharger or exhaust driven turbocharger powered by the primary engine. **The supercharger or turbo charger must pressurize the intake system above atmospheric pressure.** This will also include systems such as turbo compounding.

**For purposes of running up in class, normally aspirated engines may be classified as Blown.**

#### **4.GG TECHNICAL ADVISORY COMMITTEE:**

A group of competitors, manufacturers' representatives and others appointed by the LTA Board to review and update the competition rules of LTA.

#### **4.HH WHEELBASE:**

All vehicles must have at least two parallel axles. The wheelbase is the distance measured from the centerline of the rear axle to the transverse center line of the front spindles. The wheelbase must be equal on the left and right sides of the vehicle to within 1 in.

NOTE: Streamliners are exempt from this rule.

**4.II DRIVESHAFT:**

A driveshaft is defined as the connection from the engine or transmission to the rear drive unit in a conventional front engine/rear drive configuration.

**4.JJ BUMPER:**

A bumper is a metal device that bolts to a car's chassis to provide collision protection and may be removed in some classes. A bumper is typically 16-20 in. above the road surface. Bumper covers (thermoplastic body pieces on cars starting in 1978) are considered to be part of the body. The bumper cover cannot be removed or altered in shape and contour if not allowed by class rules. For the purposes of streamlining, any fascia covering the primary bumper bar ceases to be part of the bumper once above or below the primary impact absorbing region.

**4.KK OEM BODY KIT:**

Body kits produced by an automobile manufacturer for a specific year vehicle must be used as a complete package. 500 kits for the same model were/are required to be for sale to the general public meets the production requirements. Mixing and matching pieces from different years or not using the complete kit will be considered streamlining.